

ASCENT X¹ QUICK START GUIDE



1 Carefully unpack box.

2 Unlock and open front panel of unit for access to internal components.

! IMPORTANT!

We recommend mounting Ascent on a gooseneck pedestal with the included hardware.

If using alternate mounting, the optional **Ascent 10' Cable Extension (p/n 16-X-EXT)** should be purchased. Follow the instructions included with the extension before moving on. **Failure to do so may result in no signal!**

Continued on next page...

What's what?

All the important components labeled for you.

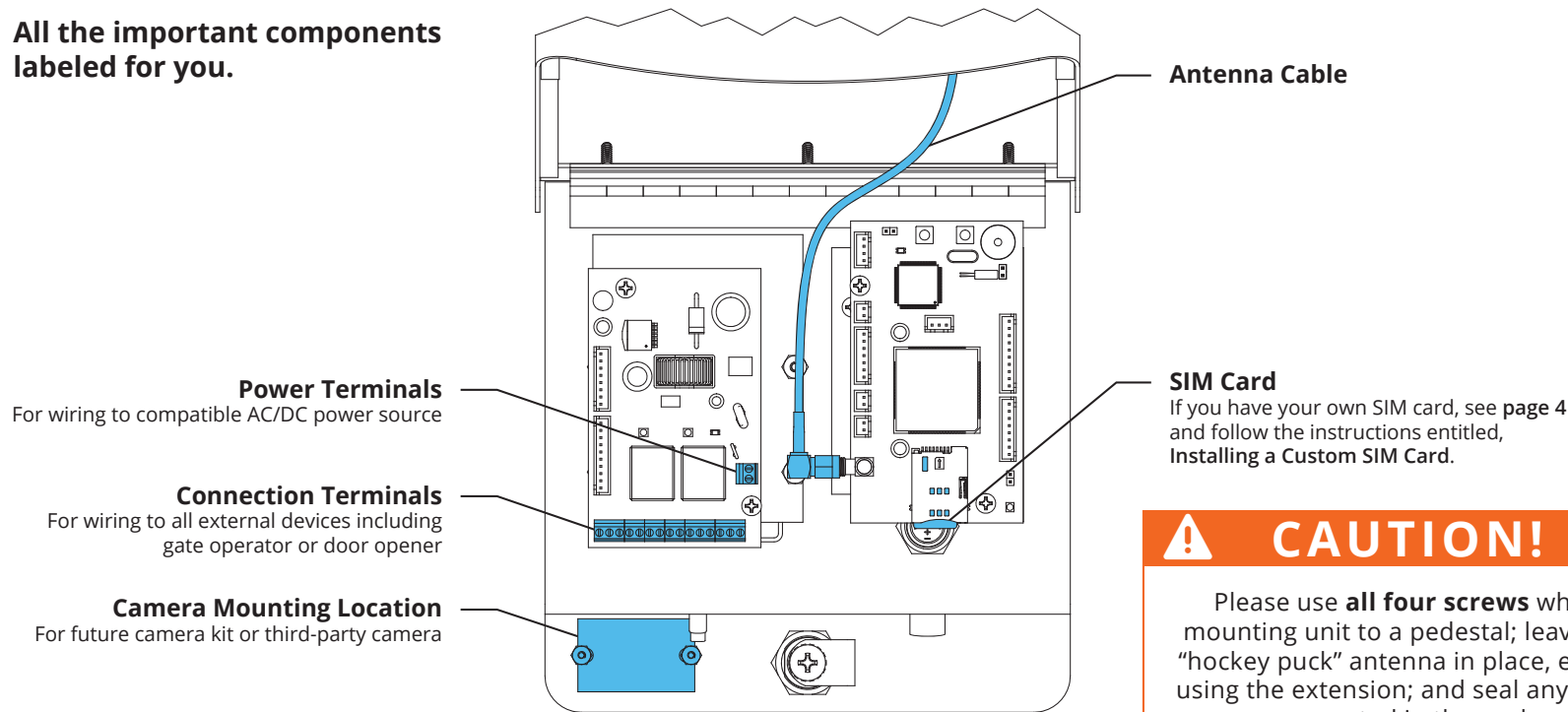

Unit shown with front panel fully open. Internal wiring not shown for clarity.

! CAUTION!

Please use **all four screws** when mounting unit to a pedestal; leave the "hockey puck" antenna in place, even if using the extension; and seal any holes or gaps created in the enclosure.

Failure to follow these instructions can result in damage to the unit!

! IMPORTANT!

Ascent **WILL NOT WORK** until the activation process is **COMPLETE!**

Follow the **Activation Guide** or call **Summit Control at (844) 259-8265** to activate your unit.

! WARNING!

AUTOMATIC GATES CAN CAUSE SERIOUS INJURY OR DEATH!

ALWAYS CHECK that the **GATE PATH IS CLEAR BEFORE OPERATING!**

Reversing or other safety devices should **ALWAYS BE USED!**

3 Connect wires

Feed wires through back of unit and connect as shown.

Ascent Power Terminals

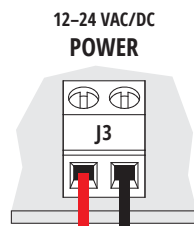

Third-Party 12-24-VAC/DC Power Source

OR

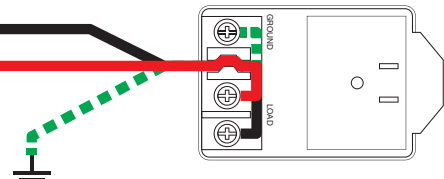

Supplied 12-VAC Transformer

The GROUND terminal is optional unless required by local code(s). If using, please connect to earth ground or equivalent.

Ascent Connection Terminals

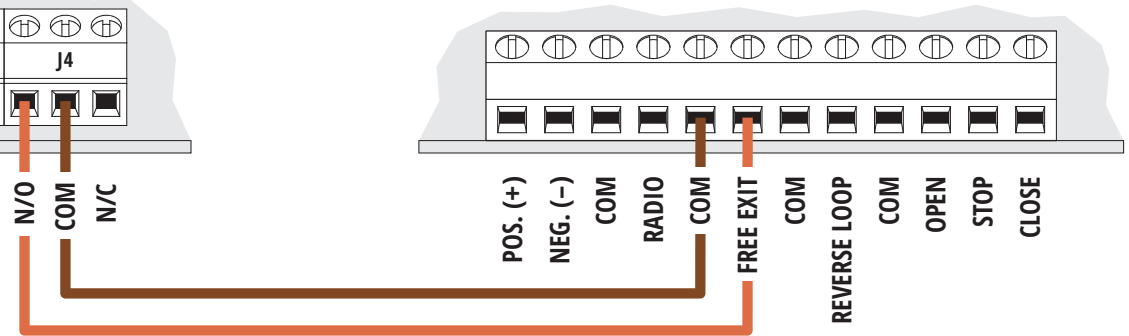
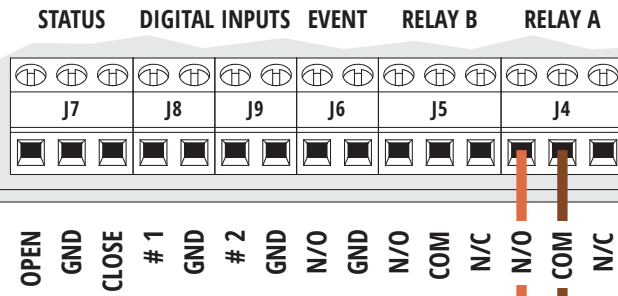

Relay B can be wired to a second device in the same manner.

CAUTION!

If you will not be using the supplied 12-VAC transformer, please go to **page 4** and follow the procedure, **Using a Third-Party Power Source**.

Do not exceed 24 VAC/DC! Failure to choose a compatible power source can damage unit!

STOP!

Before proceeding, double check that wiring is correct and unit has power!

For additional wiring options, see **page 3**.

4 Close and lock front panel.

5 Make sure gate path is clear, then key in temporary code 2012 on keypad and confirm gate opens.

2
0
1
2

Adding and deleting codes is done through Summit Control and **NOT** from the keypad!

INSTALLATION COMPLETE!

Now follow the **Activation Guide** to create an account and begin using Ascent.

A Status Check

Wiring to enable Gate Status Check

Ascent Connection Terminals

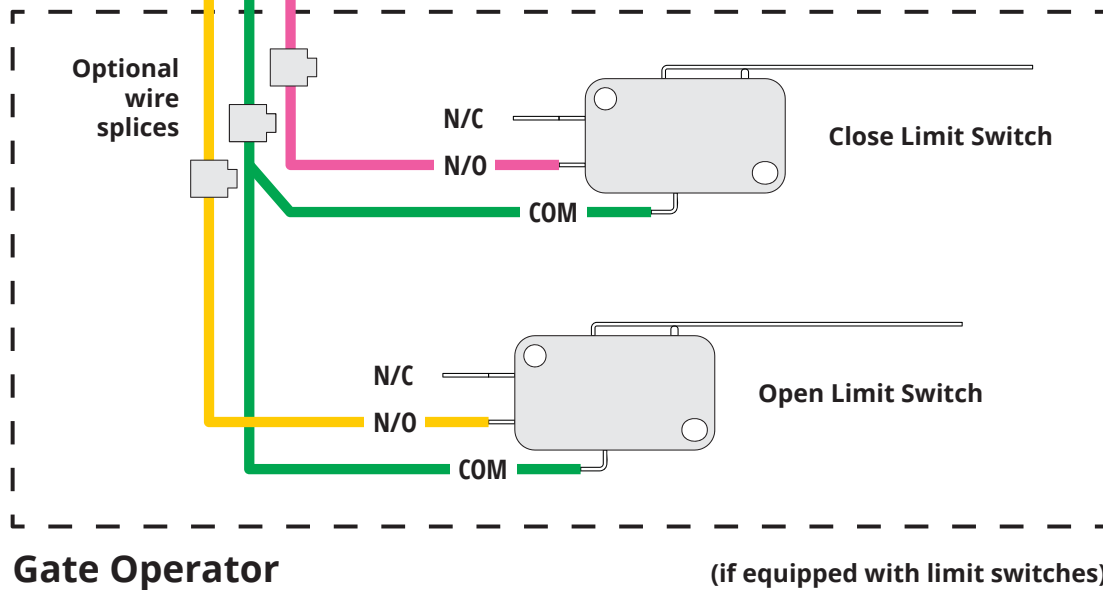
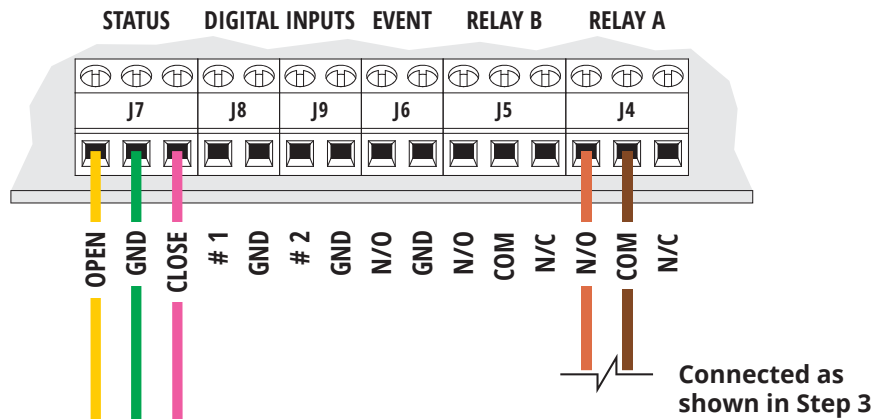

B Event Input

Wiring for accessories such as a request-to-exit device

Ascent Connection Terminals

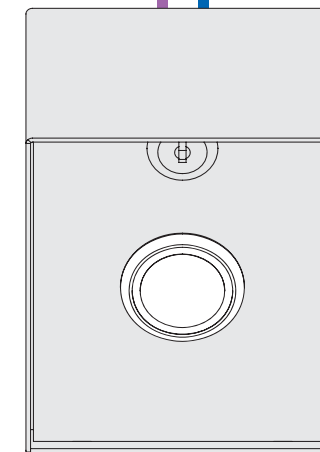
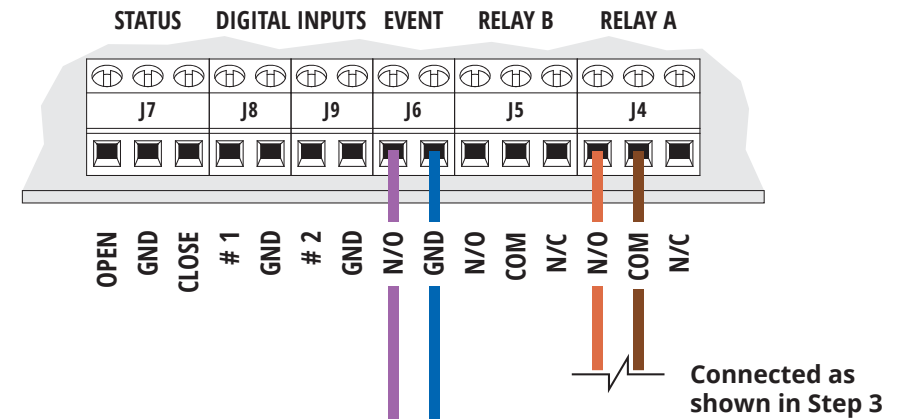

Request-to-Exit

(Summit Access Control S-RTE-P is shown)

Using a Third-Party Power Source (Optional)

IMPORTANT!

If you would like to use a third-party power source, such as solar, verify that it conforms to the following specs:

Input	12–24 VAC/DC no more than 10% under or over
Current Draw	less than 90 mA @ 12 VDC less than 60 mA @ 24 VDC

3a Connect wires to unit as shown in Step 3.

3b Connect wires to your power source, making sure you connect positive to positive and negative to negative.

CAUTION!

Double check that you've wired from positive on Ascent to positive on your power source and negative on Ascent to negative on your power source.

Reverse polarity can damage Ascent!

Installing a Custom SIM Card (Optional)

1 Push existing SIM card in until it unlocks with "click" sound.

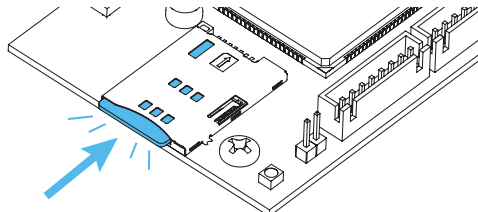

2 Remove existing SIM card and locate new SIM card.

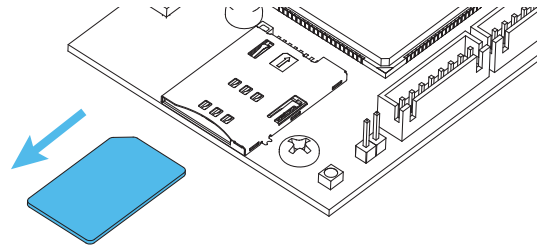

3 Insert new SIM card until it locks in place with "click" sound.

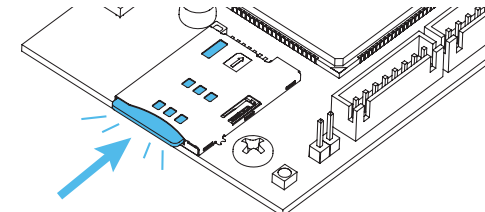

NEED HELP

Call us at (844) 259-8265
or visit summitcontrol.com/contact
We are available **Mon-Fri / 8am-5pm Central**